

1st scrutiny plan.

A2/20034/226

26/8/11

NOTE:- THIS LAYOUT WAS APPROVED
IN L.P.D.M/D.T.P NO: 9/74 BY
THE JOINT DIRECTOR OF TOWN &
COUNTRY PLANNING.

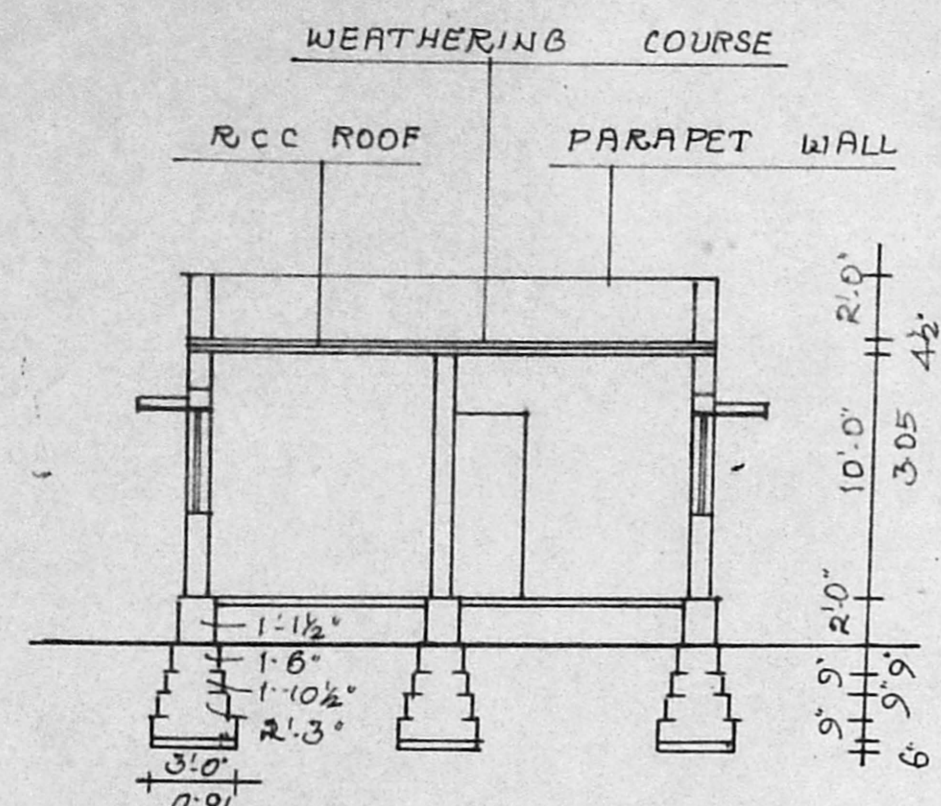

SECTION ON AA

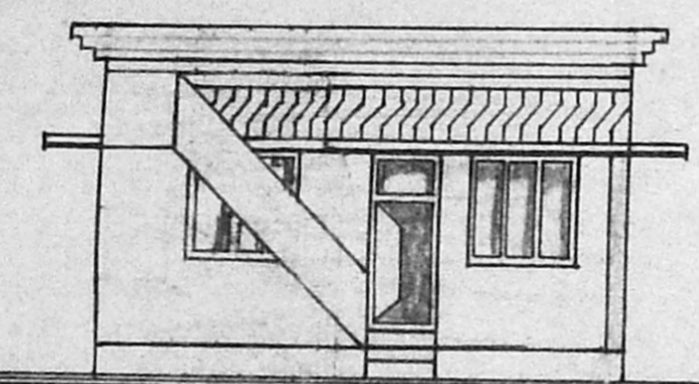

FRONT ELEVATION

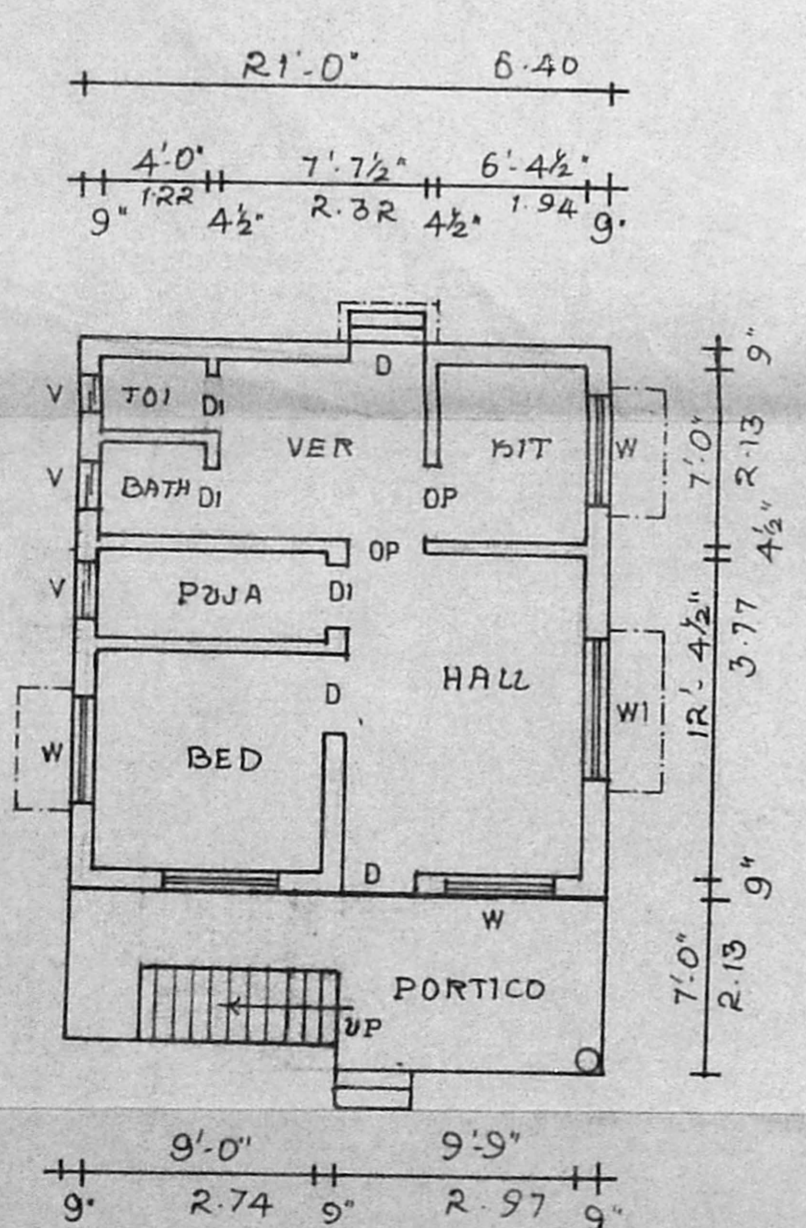

GROUND PLAN

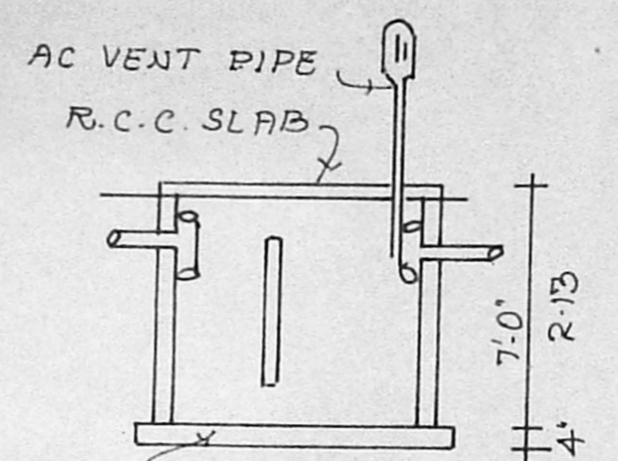

APPROVED
SUBJECT TO THE CONDITIONS IN
THIS OFFICE LETTER.
No. A2/20034/226 Date: 29-11-96
FOR MEMBER SECRETARY
MADRAS METROPOLITAN
DEVELOPMENT AUTHORITY
MADRAS - 600 008.

KEY PLAN
NOT TO SCALE

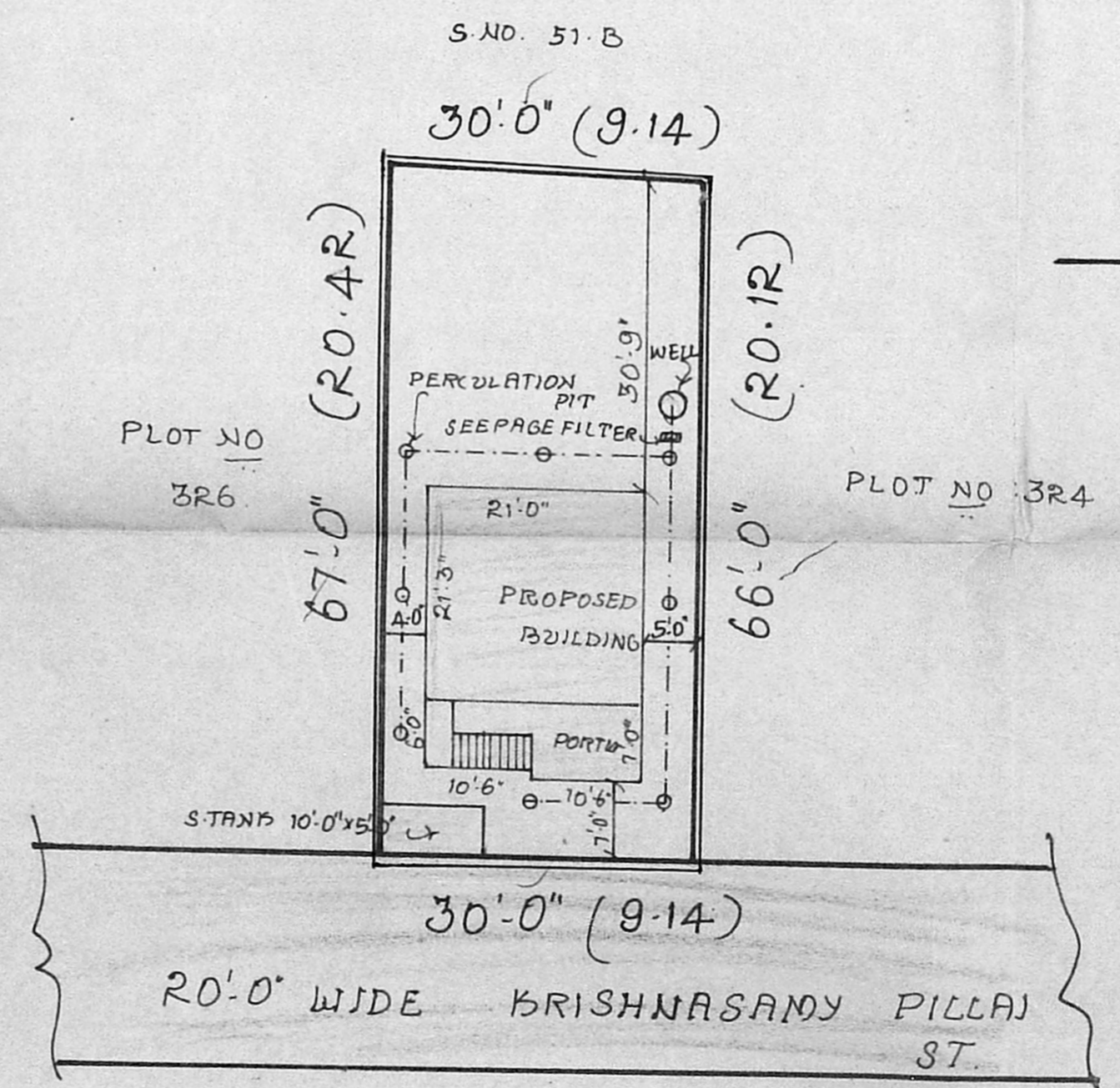
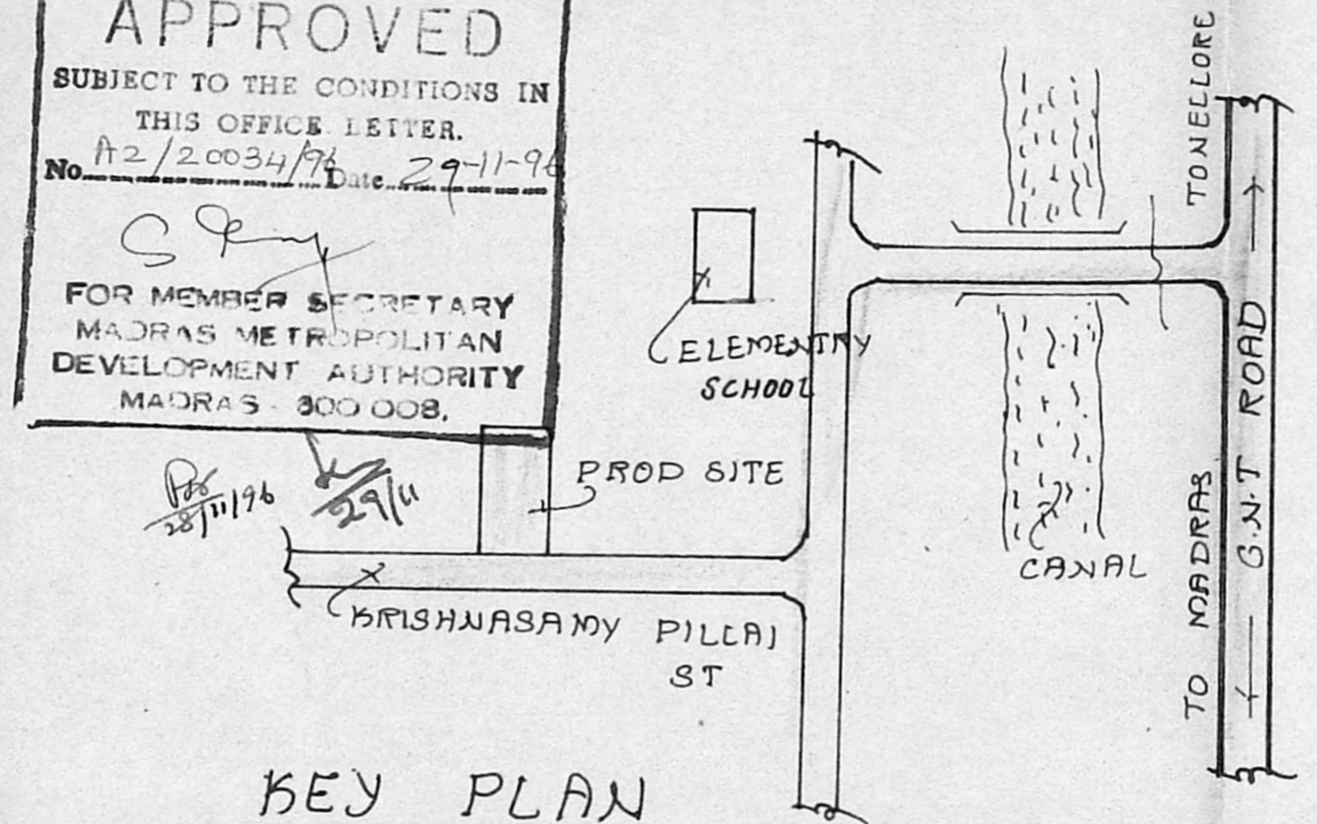

SITE PLAN
SCALE : 1" = 16'0" OR 1:200.

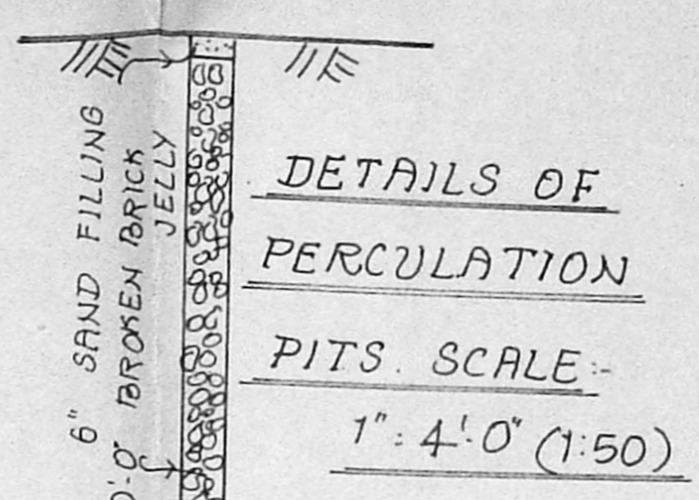

PLAN SHOWING THE PROPOSED CONSTRUCTION
OF RESIDENTIAL BUILDING IN S.NO 51, PLOT
NO: 3R5 AT BALAMURUGAN NAGAR,
ATTANTHANGAL VILLAGE, PONNERI TALUK,
CHENGAI M.G.R. DISTRICT. SCALE: 1" = 8'0" (1:100)

OWNER:- THIRU. R. RAMESH & THIRU. R.V. RAMANI.

SPECIFICATIONS:-

- MASONRY STOCK BRICK IN CM 1:6.
- FOUNDATIONS STONE JELLY CON IN CC 1:4:8.
- FLOORING 3/4" THICK IN CM 1:4.
- 4" THICK BJ LIME CON IN CC 1:2:5.
- PLASTERING 1/2" THICK IN CM 1:4.

REFERENCE:-

- DOOR D: 3'0" x 7'6"
- DOOR D1: 2'6" x 6'6"
- WINDOW W: 4'6" x 4'6"
- WINDOW W1: 5'6" x 4'6"
- VENTILATOR V: 2'0" x 1'0"

AREA DETAILS:-

- PLOT AREA : 1995.0 SFT OR 186.0M²
- PLINTH AREA : 446.0 SFT OR 42.0M²
- PORTICO & STAIR : 138.0 SFT OR 13.0M²
- PLOT COVERAGE : 29%

COLOUR INDEX:-

- PROPOSED [Symbol]
- ROAD [Symbol]
- BOUNDARY [Symbol]

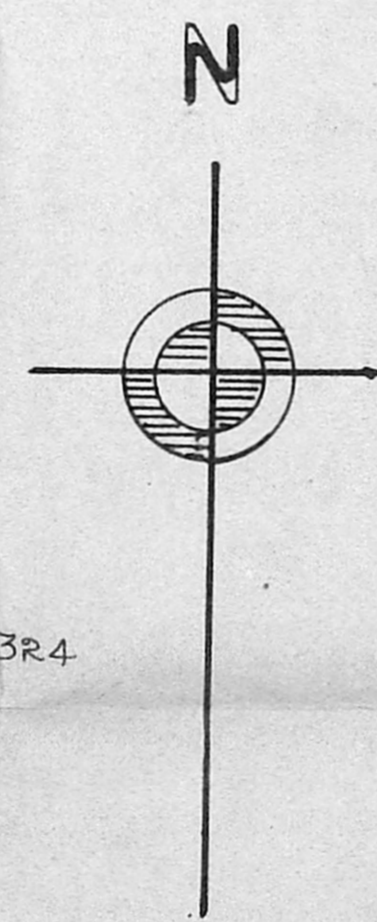

M. SUMATHI D.C.E.
LICENCED SURVEYOR
LICENCE No 172
CORPORATION OF MADRAS
6, BYE PASS ROAD,
Opp. Lakshmi Theater,
REDHILLS, MADRAS - 600 062.

OWNER

ENGINEER